

**STATE OF HAWAII  
DEPARTMENT OF DEFENSE  
OFFICE OF THE ADJUTANT GENERAL  
3949 DIAMOND HEAD ROAD  
HONOLULU, HAWAII 96816-4495**

**ADDENDUM NO. 1  
YCA Hilo Billet Shower Renovation, Hawaii  
DOD Job No. CA-1605-C1**

The items listed hereinafter are hereby made a part of the contract for the above-mentioned project and shall govern the work taking precedence over previously issued contract documents governing the items mentioned. Receipt of this addendum is to be acknowledged on page OF-6 of the proposer's packet.

**CLARIFICATIONS:**

1. HAZMAT Material:
  - a. The billet was originally built circa 2010. None of the materials installed at that time contained lead or asbestos.
  
2. Material substitutions:
  - a. This job is subject to Hawaii County Permitting. All materials used for construction will require submittals to be reviewed by the Engineer.
  
3. A revised Notice to Bidders is attached to this Addendum.

**CHANGES TO DRAWINGS:**

1. **Revised Drawings:** The following previously issued drawings dated February 2024 are revised and reissued. Under this addendum these revised drawings supersede the previously issued drawings:

<b>Sheet Group</b>	<b>Sheet No.</b>	<b>Sheet Name or Description</b>
ARCHITECTURAL	A11	Revised note
ARCHITECTURAL	A12	Added note

Kenneth S. Hara  
Major General  
Adjutant General

Posted: March 18, 2024

ATTACHMENT 1

STATE OF HAWAII  
DEPARTMENT OF DEFENSE  
OFFICE OF THE ADJUTANT GENERAL  
3949 DIAMOND HEAD ROAD  
HONOLULU, HAWAII 96816-4495

**NOTICE TO BIDDERS**

SEALED BIDS for furnishing labor, materials, tools and equipment for "YCA HILO BILLET, SHOWER RENOVATION, STATE OF HAWAI'I, DEPARTMENT OF DEFENSE, JOB NO. CA-1605-C1" will be received in the Engineering Office, State of Hawaii, Department of Defense, located in Building 306-A, Room 228, 3949 Diamond Head Road, Honolulu, Hawaii, up to 2:00 P.M. on March 28, 2024 and will then and there be publicly opened and read aloud. Bids may also be mailed to State of Hawaii, Department of Defense, 3949 Diamond Head Road, Honolulu, HI, 96816-4495, ATTN: HIENG, Room 228. Bids must be received in the Engineering Office, Room 228, prior to the time and date fixed for opening to be considered. All bids received in the Engineering Office after the time and date fixed for opening will not be considered.

Bidders are advised that the Department of Defense facility at 3949 Diamond Head Road is a secure facility. In order to access the property, Bidders and/or their authorized personnel shall present a current driver's license or other form of official identification (with photograph) to the security personnel at the entry gate, and shall inform the security personnel of the building and room number they require access to (State Contracting Section 369-3491). Lack of official identification or knowledge of the building and room to which access is needed are grounds for denial of access onto the property.

Bidders should be aware and allow for security screening and random vehicle inspections. The state will not be responsible for late bids due to the afore mentioned reasons.

Proposed work consists of, but not limited to the following: Renovation of Boy's and Girl's Shower Rooms at the YCA Hilo Billet and other project related work.

The estimated cost is between \$250,000 and \$500,000.

A Site Visit will be held on **March 14, 2024 at 2:30pm**. The Pre-Bid meeting/Site Visit will be held YCA Hilo; contractors are to meet Mr. Jim Barbour at 1046 Leilani St (Keaukaha Military Reservation), Hilo, HI 96720. Please call Jim Barbour at 808-369-3492 before **4:30 PM** on **March 12, 2024** to register for the site visit. If no response, please leave message giving information of company name, name of all individuals that will attend, and contact phone number. All interested bidders and sub-contractors are welcome, but not required to attend.

*Bona fide bidders may obtain copies of applicable specifications and bidding documents at the above named office. All documents can be downloaded from the State Procurement Office website at <http://spo.hawaii.gov/> and at the State Department of Defense website at <http://dod.hawaii.gov/hieng/>. If prospective bidders obtain copies of the bid documents from sources other than the Contracting and Engineering Office address listed above, then bidders are responsible to register by sending their company name, address, telephone and facsimile number, and email address via email to [cathy.a.siu@hawaii.gov](mailto:cathy.a.siu@hawaii.gov).*

All requests for substitution, clarification of bidding documents and/or specifications must be received in the office listed above, via email, prior to **March 15, 2024, 4:30 pm**. Questions shall be emailed to [jesper.h.andersen@hawaii.gov](mailto:jesper.h.andersen@hawaii.gov) .

Late submittals for this solicitation will not be reviewed by this agency.

An Intent to Bid is NOT required to be submitted for this project.

Bidders are required to register on the Hawaii Compliance Express web site for all tax clearances by going to <http://spo.hawaii.gov/> click on “HCE” and registering there.

Bidders are responsible for checking for any addenda for this project. The addenda will be posted on the State Procurement Office web site under the project name at <http://spo.hawaii.gov/>

The Hawaii Products preference pursuant to ACT 175, SLH 2009 may be applicable for numerous items throughout this solicitation. Persons wishing to certify and qualify a product not currently listed as a Hawaii Product shall submit a Certification for Hawaii Product Preference (form SPO-38) by e-mail to [jesper.h.andersen@hawaii.gov](mailto:jesper.h.andersen@hawaii.gov) prior to **4:30pm 15 days prior to the bid opening** date for this project. View the current Hawaii Products List on the State Procurement office (SPO) website at <http://hawaii.gov/spo>.

For each product, one form shall be completed and submitted (i.e. 3 products should have 3 separate forms completed). The form is available on the SPO webpage at <http://hawaii.gov/spo>.

**CAMPAIGN CONTRIBUTIONS BY STATE AND COUNTY CONTRACTORS PROHIBITED.** If awarded a contract in response to this solicitation, offeror agrees to comply with HRS §11-355, which states that campaign contributions are prohibited from a State and County government contractor during the term of the contract if the contractor is paid with funds appropriated by the legislative body between the execution of the contract through the completion of the contract.

#### **REQUIREMENT FOR CONTRACTORS LICENSING CLASSIFICATIONS**

Due to the nature of the work contemplated bidder must possess a valid State of Hawai‘i Contractor’s license classification(s) B.

General Engineering Contractors holding an ‘A’ license and General Building Contractors holding a ‘B’ license are reminded that due to the Hawaii Supreme Court’s January 28, 2002 decision in Okada Trucking Co., Ltd. v. Board of Water Supply, et al., 97 Haw. 450 (2002), they are prohibited from undertaking any work, solely or as part of a larger project, which would require the General Contractor to act as a specialty Contractor in any area in which the General Contractor has no license.

Bidders are solely responsible to review the project requirements, determine the appropriate licenses required, and ensure that they possess and that the Subcontractor(s) listed in their OFFER FORM possess the necessary specialty licenses to perform the work for this project.

Kenneth S. Hara  
Major General  
Adjutant General

Posted on: February 28, 2024

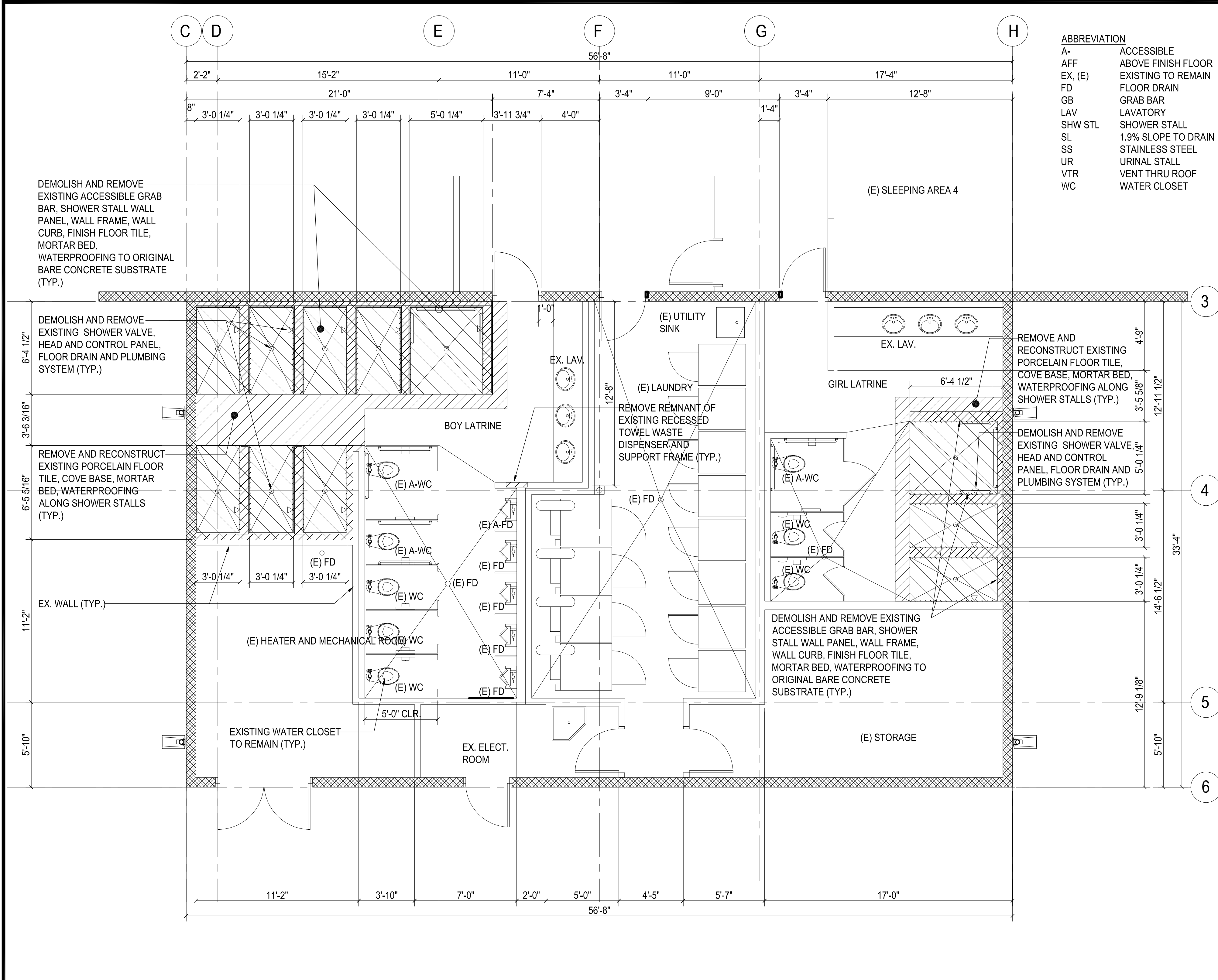

**A1 FLOOR DEMOLITION PLAN**  
 A11 SCALE: 1/4"= 1'-0"

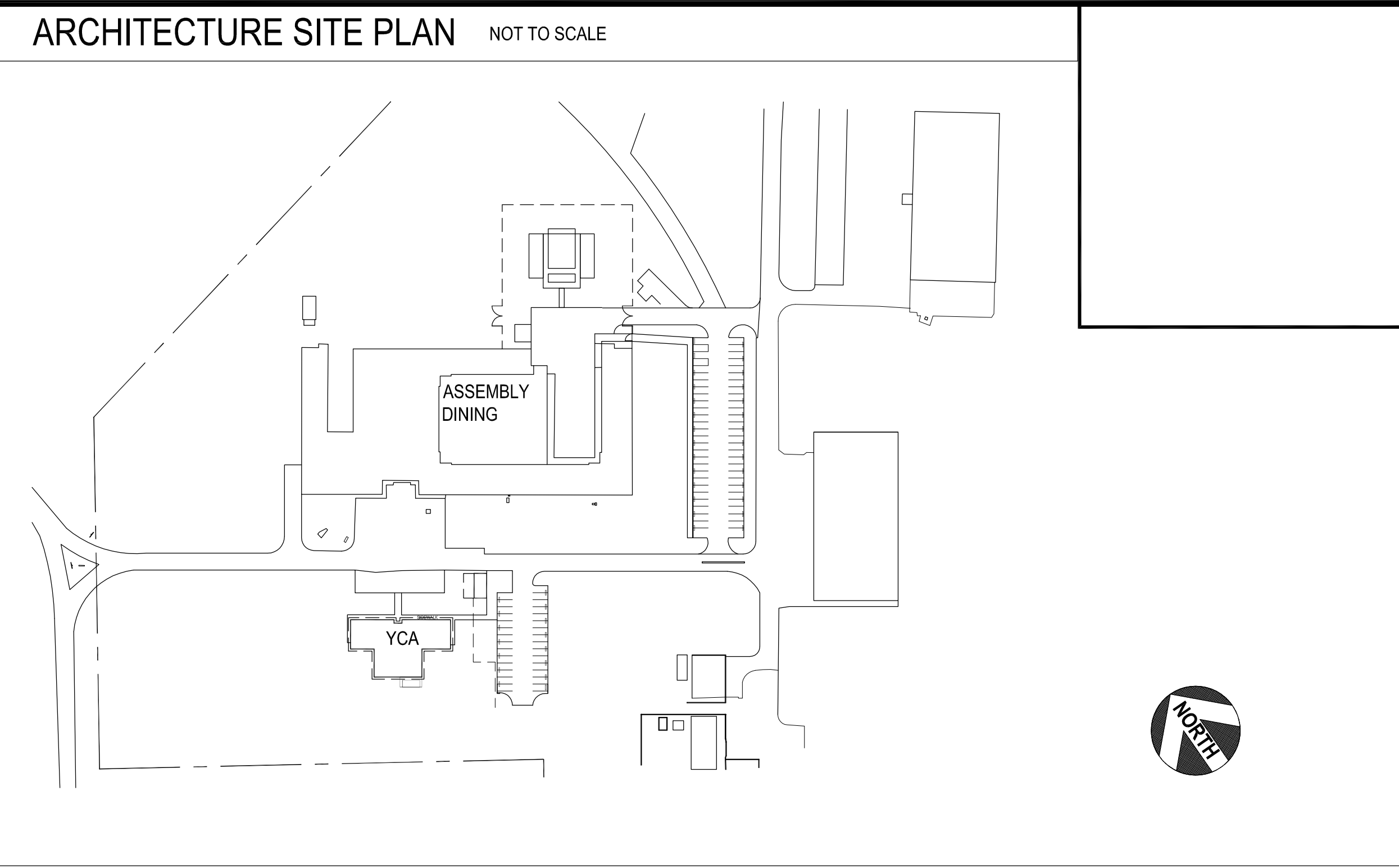
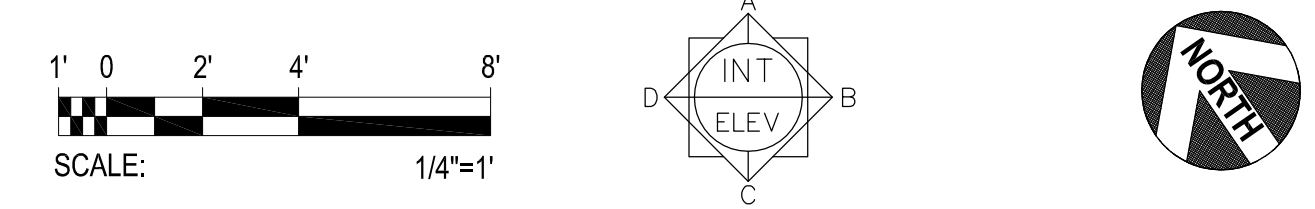

**PHASING PLAN** SCALE: 1/8"= 1'-0"  
 TO MINIMIZE DISRUPTION TO THE OPERATION OF YOUTH CHALLENGE ACADEMY, HILO BILLET SHOWER RENOVATION, RENOVATION WORK SHALL BE SECTIONED IN TWO PHASES. GENERALLY CONTRACTOR SHALL COMPLETE ALL THE WORK IN ONE PHASE BEFORE PROCEEDING TO NEXT PHASE. WORK IN BETWEEN TWO PHASES MAY BE COMPLETED UNDER THE SUBSEQUENT PHASE. THE SEQUENCE OF CONSTRUCTION SHALL BE ADJUSTED AND SHALL BE DETERMINED BY THE CONTRACTING OFFICER.

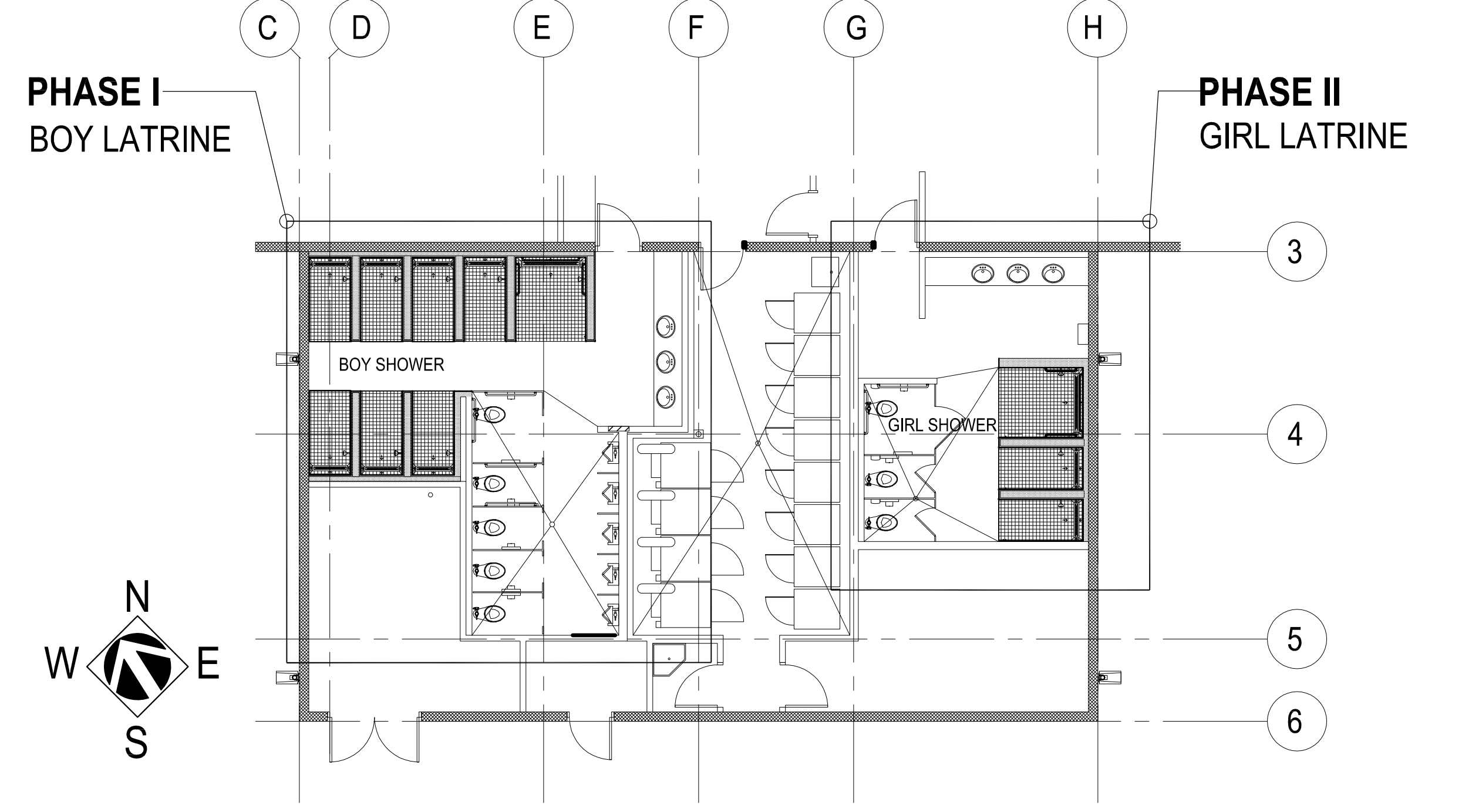

**DEMOLITION AND REMOVAL NOTES**

**SHOWER STALL**  
 CONTRACTOR SHALL DEMOLISH, REMOVE AND DISPOSE OF EXISTING SHOWER STALLS INSIDE BOY AND GIRL LATRINES. DEMOLITION WORK SHALL INCLUDE, BUT NOT BE LIMITED TO SHOWER STALL PARTITION WALL, WALL FRAME, FINISH WALL PANELS, FINISH FLOORING SYSTEMS, WATERPROOFING MEMBRANE, MORTAR BEDS, FLASHING, SEALANT, WATER, DRAIN, VENT THRU ROOF PIPES AND PLUMBING SYSTEM. SAWCUT, CHIP AND GRIND EXISTING CONCRETE SUBSTRATE FOR FLOOR DRAIN AND CONSTRUCTION OF FLOOR SLOPES.

**CONCRETE FLOOR SLAB AND CEILING**  
 DEMOLITION SHALL INCLUDE, SAW CUTTING, EXCAVATING EXISTING CONCRETE SLAB FOR RAISED CONCRETE CURBS AND UNDERGROUND PLUMBING WORK. CUTTING AND MODIFY EXISTING CEILING AND FRAME FOR VENTILATION WORK. REMOVE EXISTING WALL MOUNTED LIGHTING, UNUSED AND ABANDONED WIRING, DISMANTLE AND REMOVE ALL ABANDONED METAL SUPPORTS, WOOD BLOCKING, COVER, CONCRETE CURBS, DUCT AND PIPE SUPPORTS, PROVIDE TEMPORARY SHORINGS, SUPPORTS, BRACING AND ENCLOSURE TO EXISTING DECK, DUCTING AND MECHANICAL EQUIPMENT FOR THE REMOVAL WORK AS REQUIRED. CONTRACTOR SHALL VERIFY THE EXISTENCE AND CONDITION OF EXISTING SHOWER UNDERLAYMENT, WATERPROOFING, MORTAR BED, REMOVE, CLEAN AND REPAIR LOOSE, DAMAGED, AND UNSUITABLE UNDER FLOOR MATERIAL TO PROVIDE A PROPER SUBSTRATE FOR BUILT-UP SLOPED MORTAR BED AND SHOWER STALL FLOOR.

**EXISTING FLOOR TILE AND WALL BASE**  
 CONTRACTOR SHALL CHIP OFF AND REMOVE EXISTING DAMAGED AND LOOSE PORCELAIN FLOOR TILE AND CURVED COVE BASE FOR REPLACEMENT, PORTION OF EXISTING PORCELAIN FLOOR TILE AND CURVED COVE BASE AT FLOOR TILE TRANSITION BETWEEN EXISTING AND NEW FLOOR TILE FOR A SMOOTH AND LEVELED TRANSITION.

**SALVAGE, REUSE AND REINSTALLATION WORK**  
 EXISTING ITEMS CALLED OUT TO REMAIN SHALL BE COVERED AND PROTECTED IN PLACE. EXISTING FURNITURE, EQUIPMENT AND MOVABLE ITEMS IN THE WAY OF RENOVATION SHALL BE REMOVED AND RELOCATED TO AREAS DESIGNATED BY THE CONTRACTING OFFICER. ITEMS CALLED OUT TO BE REUSED AND/OR REINSTALLED INCLUDING LIGHTING AND PLUMBING WORK, CEILING AND WORK ACCESS PANELS SHALL BE DISMANTLED AND SAVED FOR REINSTALLATION. BUILT-IN AND FIXED ITEMS TO BE SALVAGED DURING CONSTRUCTION SHALL BE DISMANTLED, CLEANED, PLACED IN PROTECTIVE WRAPPING OR BOXES AND STORED IN AREA(S) DESIGNATED BY THE CONTRACTING OFFICER. CONTRACTOR SHALL FIELD VERIFY EXISTING CONDITION, CAREFULLY DISMANTLE, REMOVE AND STORE ITEMS TO A SAFE AND PROTECTED AREA UNTIL REINSTALLATION.

ADD-1	1	REVISED NOTE	1 of 2	MAR 18 2024	
REVISION NO.	SYMBOL	DESCRIPTION	SHT. OF	DATE	APPROVED DDD
DEPARTMENT OF DEFENSE STATE OF HAWAII <b>YCA HILO BILLET SHOWER RENOVATION</b> 79-1020 HAUKAPILA STREET, KONA HAWAII 96750 TAX MAP KEY: (3) 7-9-013:017					
<b>FLOOR DEMOLITION PLAN</b> LOU CHAN & ASSOCIATES, INC. JOB NO. CA-1605-C2 DRAWING NO. A11 DESIGN BY: LCC CHECK BY: LCC DRAWN BY: NS APPROVED BY: LCC DATE: FEBRUARY 2024 SHEET 3 OF 12 SHTS. SCALE: AS NOTED					

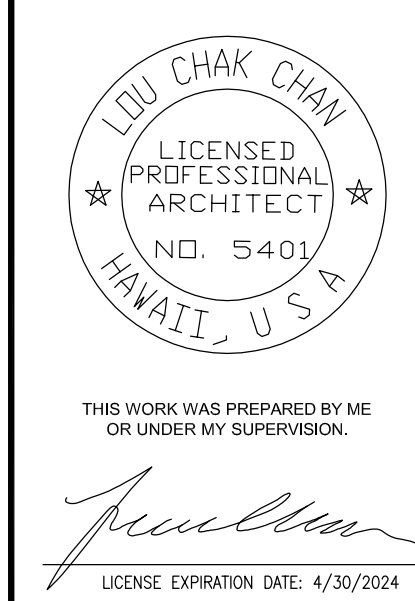

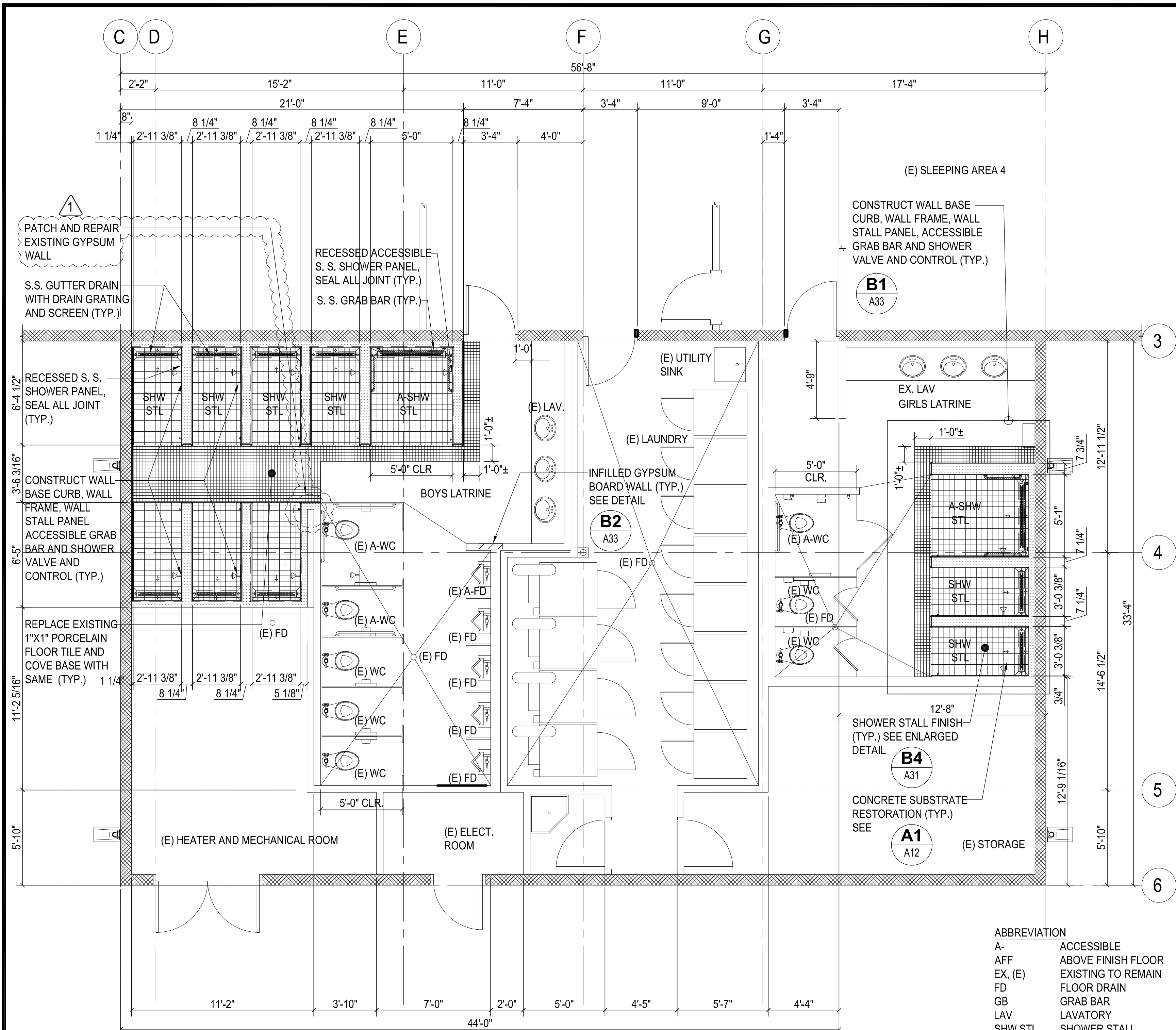

**B1 FLOOR RENOVATION PLAN**  
 SCALE: 1/4" = 1'-0"  
 1" 0 2' 4' 8'  
 SCALE: 1/4" = 1'

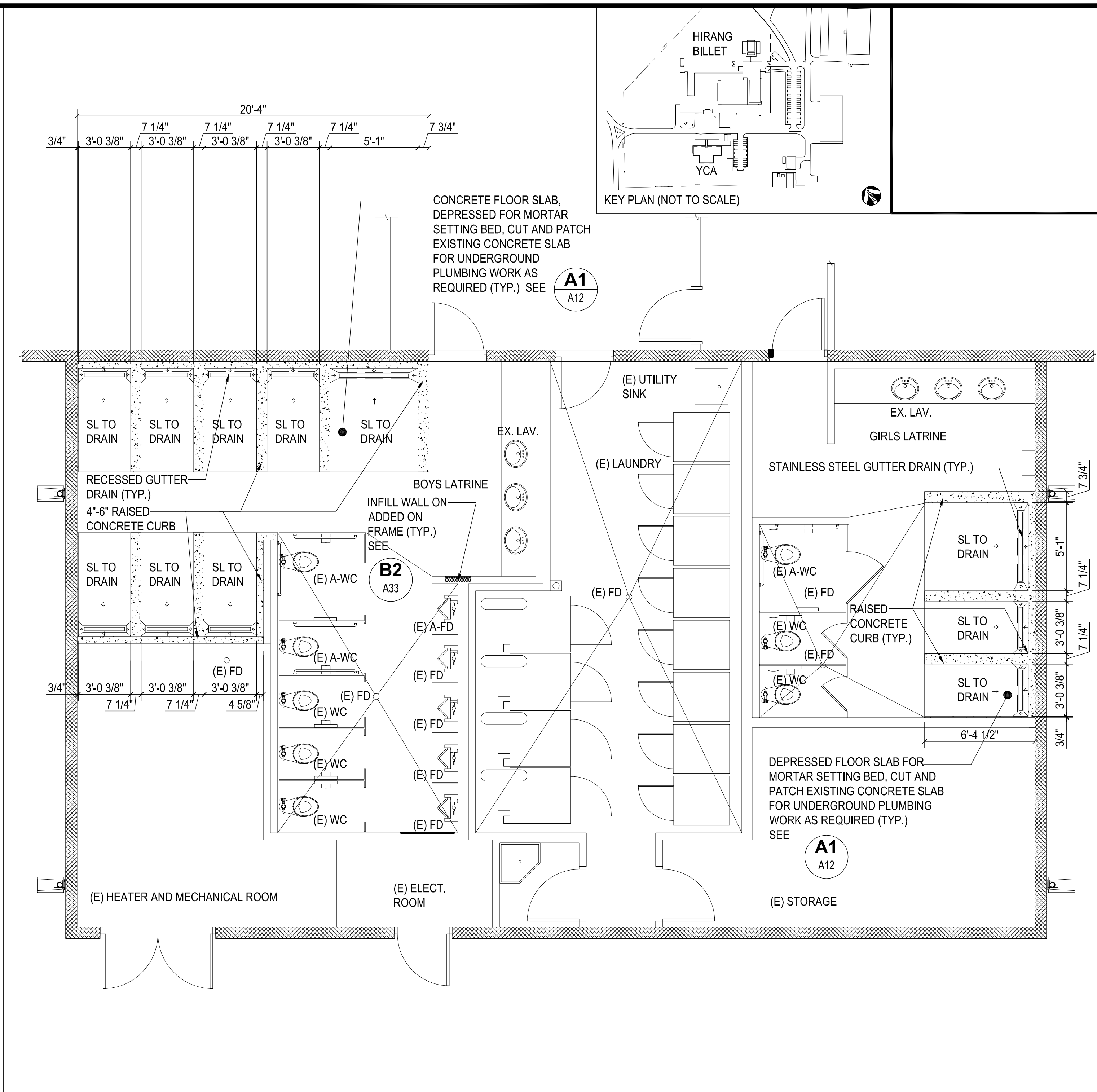

**B3 SHOWER STALL FLOOR RENOVATION PLAN**  
 SCALE: 1/4" = 1'-0"  
 1" 0 2' 4' 8'  
 SCALE: 1/4" = 1'

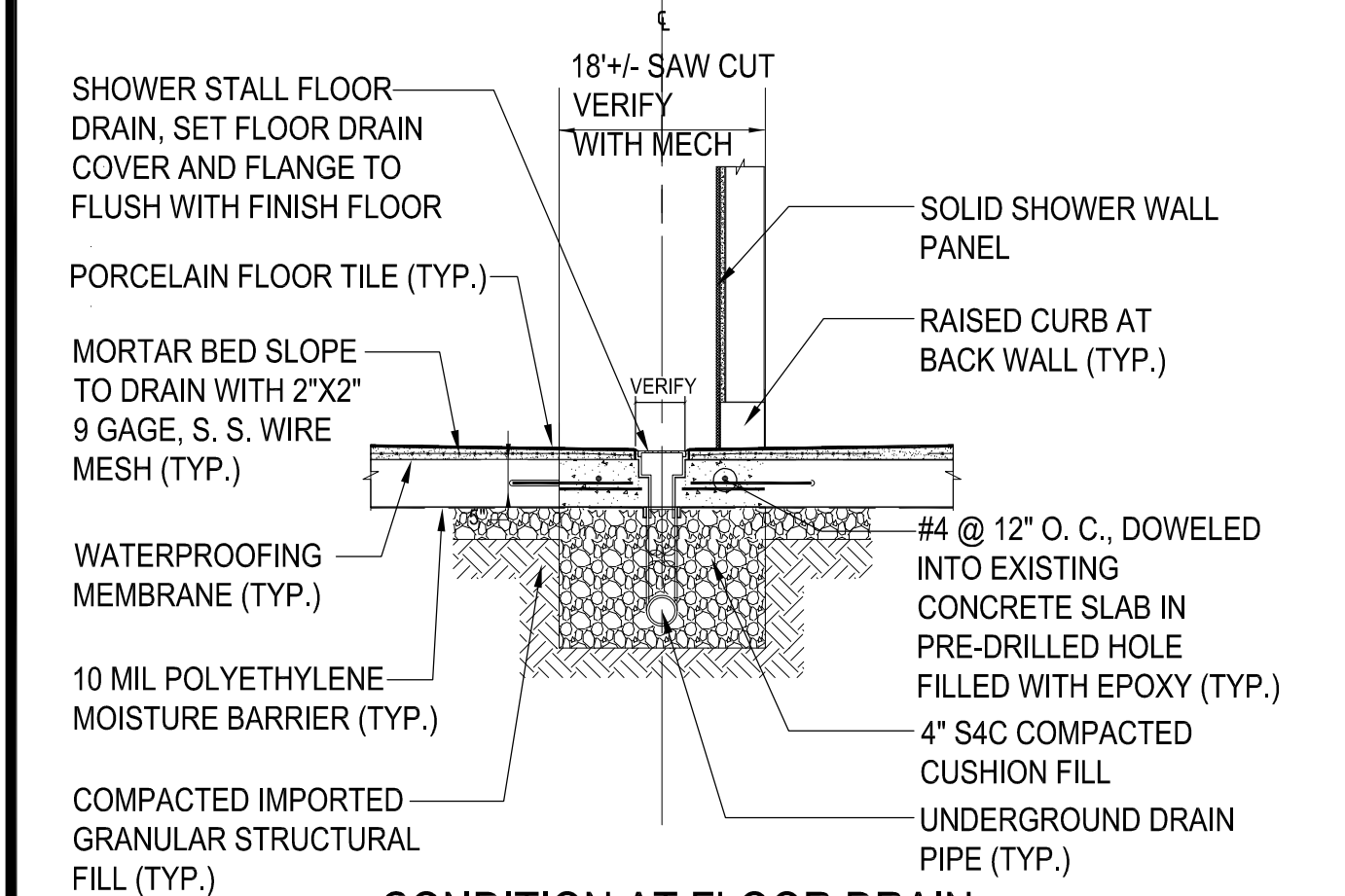

**A1 CONCRETE FLOOR SLAB RESTORATION**  
 SCALE: 1/2" = 1'-0"  
 1" 0 2' 4' 8'  
 SCALE: 1/4" = 1'

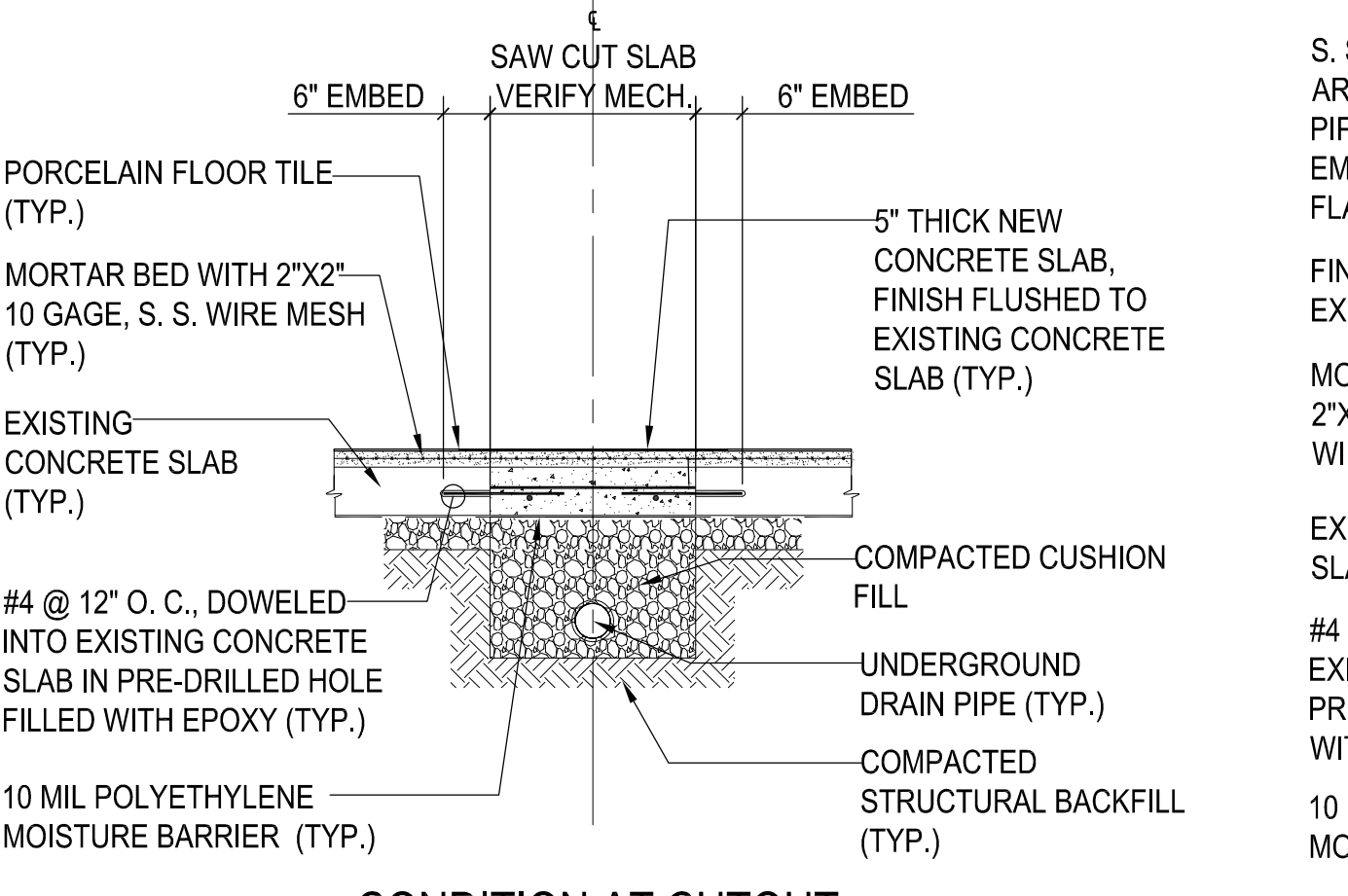

**CONDITION AT CUTOUT**  
 SCALE: 1/4" = 1'

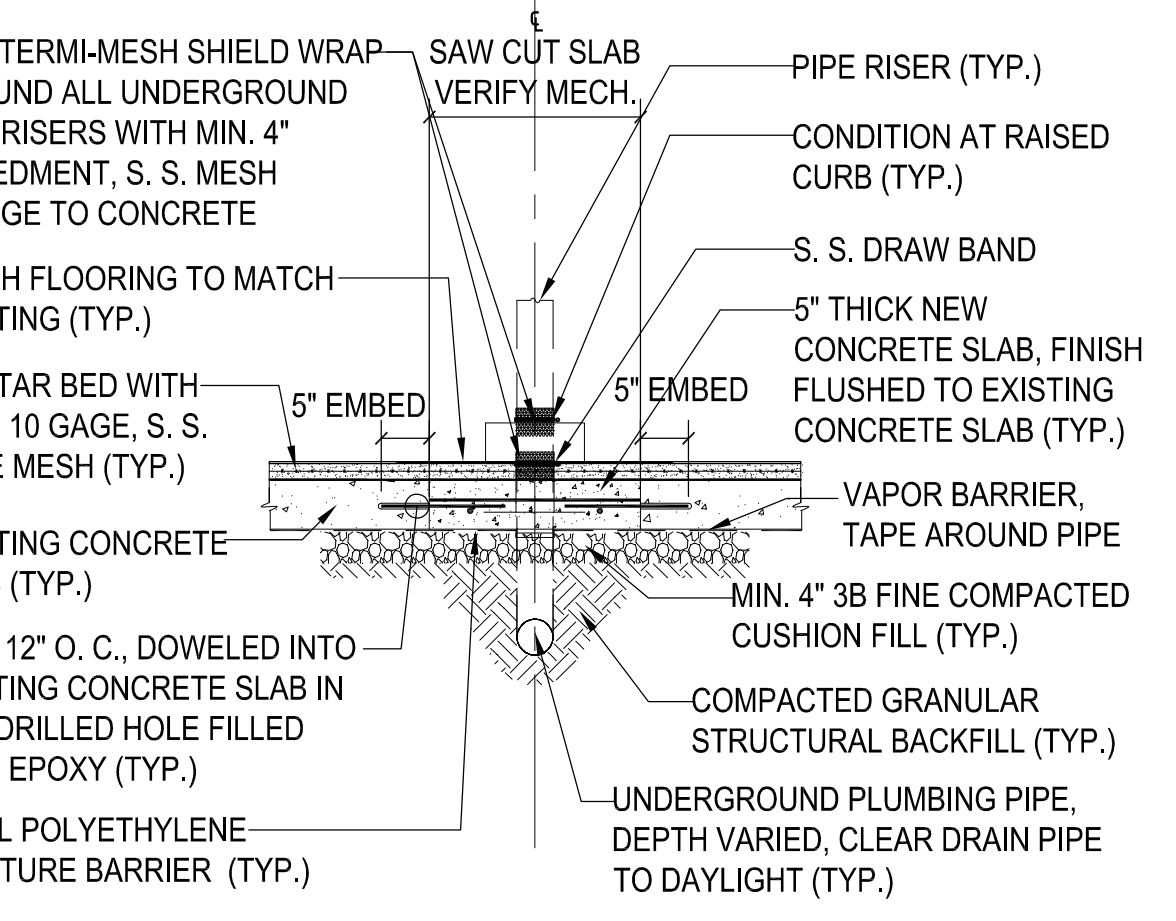

**CONDITION AT PIPE RISER**

- ABBREVIATION**
- A- ACCESSIBLE
  - AFF ABOVE FINISH FLOOR
  - EX, (E) EXISTING TO REMAIN
  - FD FLOOR DRAIN
  - GB GRAB BAR
  - LAV LAVATORY
  - SHW STL SHOWER STALL
  - SL 1.9% SLOPE TO DRAIN
  - SS STAINLESS STEEL
  - UR URINAL STALL
  - VTR VENT THRU ROOF
  - WC WATER CLOSET
- NOTE:**  
 CONTRACTOR SHALL FIELD VERIFY ALL DIMENSIONS AND SUBMIT SHOP DRAWINGS FOR REVIEW.

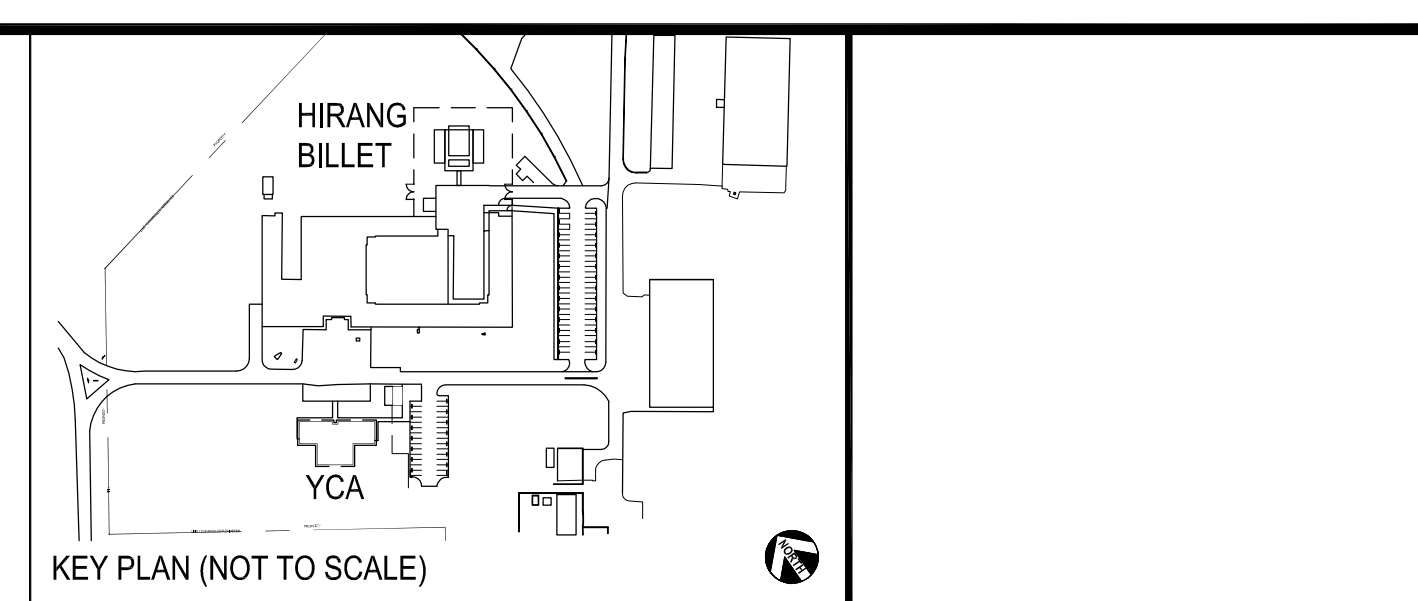

ADD-1	1	ADDED NOTE	2 of 2	MAR 18 2024
REVISION NO.	SYMBOL	DESCRIPTION	SHT. OF	DATE
DEPARTMENT OF DEFENSE STATE OF HAWAII				
YCA HILO BILLET SHOWER RENOVATION 79-1020 HAUKAPILA STREET, KONA HAWAII 96750 TAX MAP KEY: (3) 7-9-013:017				
FLOOR RENOVATION PLAN				
LOU CHAN & ASSOCIATES, INC.		JOB NO.	DRAWING NO.	
DESIGN BY:	LCC	CHECK BY:	CA-1605-C2	A12
DRAWN BY:	NS	APPROVED BY:	DATE	SHEET
			FEBRUARY 2024	4
SCALE: AS NOTED			OF 12 SHTS.	

THIS WORK WAS PREPARED BY ME OR UNDER MY SUPERVISION.  
 LICENSE EXPIRATION DATE: 4/30/2024